

Convertible Camera
AW-E600

Operating Instructions



Panasonic®

Before attempting to connect or operate this product,
please read these instructions completely.

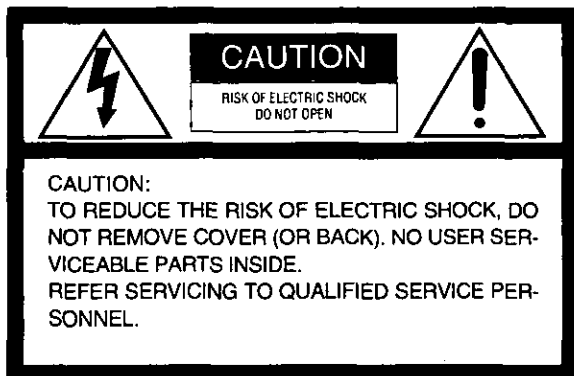

SA 1965

The lightning flash with arrowhead symbol, within an equilateral triangle, is intended to alert the user to the presence of uninsulated "dangerous voltage" within the product's enclosure that may be of sufficient magnitude to constitute a risk of electric shock to persons.



SA 1966

The exclamation point within an equilateral triangle is intended to alert the user to the presence of important operating and maintenance (servicing) instructions in the literature accompanying the appliance.

WARNING:

TO PREVENT FIRE OR SHOCK HAZARD, DO NOT EXPOSE THIS APPLIANCE TO RAIN OR MOISTURE.

For U.S.A.

NOTE: This equipment has been tested and found to comply with the limits for a Class A digital device, pursuant to part 15 of the FCC Rules. These limits are designed to provide reasonable protection against harmful interference when the equipment is operated in a commercial environment. This equipment generates, uses, and can radiate radio frequency energy and, if not installed and used in accordance with the instruction manual, may cause harmful interference to radio communications. Operation of this equipment in a residential area is likely to cause harmful interference in which case the user will be required to correct the interference at his own expense.

For CANADA

This Class A digital apparatus complies with Canadian ICES-003.
Cet appareil numérique de la classe A est conforme à la norme NMB-003 du Canada.

The information marking of this product may be found on the bottom of the unit.

The serial number of this product may be found on the bottom of the unit.

You should note the serial number of this unit in the space provided and retain this book as a permanent record of your purchase to aid identification in the event of theft.

Model No. _____

Serial No. _____

CONTENTS

PREFACE	2
FEATURES	2
SPECIAL NOTES ON OPERATION	3
PRECAUTIONS	4
MAJOR OPERATING CONTROLS AND THEIR FUNCTIONS	6
MOUNTING	10
FLANGE BACK ADJUSTMENT	12
IRIS GAIN CONTROL IN A LENS	13
CONNECTIONS	14
ADJUSTMENT	20
USE MODE SETTING	27
MENU ITEM SETTING	29
SETTING TO INITIAL SET	46
APPEARANCE	49
SPECIFICATIONS	50
STANDARD ACCESSORIES	52
OPTIONAL ACCESSORIES	52

PREFACE

The Panasonic AW-E600 is a digital signal processing color video camera that incorporates three 1/2" CCDs. A digital video signal processing system is packed in a compact, lightweight body while assuring high picture quality, high reliability and high performance. System setup and adjustments can be easily performed

by following the setup menu.

Connection to peripheral devices, such as a RCU, a RCB and a lens and the camera pan/tilt unit enables a wide variation of system configurations.

Option cards may also be installed.

FEATURES

1. Digital video signal processing for high quality, high reliability, high performance, lightweight and compact size.
2. Resolution: 850 lines (HIGH BAND DTL: ON), S/N ratio: 65 dB (DNR ON)
3. Minimum illumination: 0.25 lux (F1.4, Night eye HIGH mode)
4. SET UP menu for system check and readjustments.
5. Built-in automatic controls, including ATW, ELC, and AGC
6. CCD readout is switchable between field and frame modes. Vertical resolution can be stepped up in frame mode and it is effective for shooting still objects.
7. The built-in synchronized scanning system reduces noise in computer graphics.
8. Various correction circuits permit video reproduction with high fidelity.
9. Chroma detail correction enables clear shots of dark color objects.
10. A dark detail circuit provides natural edge correction to any object in a dark scene.

11. A digital highlight chroma circuit reproduces natural dynamic ranges.
12. A digital color matrix enables high fidelity color images.
13. Four use modes for each of your specific applications can be selected.
14. SMPTE color bar is indicated on the monitor screen.
15. Remote control with a RCU, RCB or a Hybrid control panel.

SPECIAL NOTES ON OPERATION

- Turn power off before connecting or disconnecting cables.
- Connection or disconnection of any studio cable, RCB cable or other cable to any unit of equipment must be performed while power is off.
- While the camera is in automatic mode;
Shooting of bright objects in ELC operation mode may result in a smeared picture unique to the CCD.
The ATW function under fluorescent illumination can adversely change the white balance.

PRECAUTIONS

DONT'S

- Do not attempt to disassemble the camera, Remote Control Unit (RCU) or other units. In order to prevent electric shock, do not remove screws or covers. There are no user-serviceable parts inside.
- Do not abuse the camera. Avoid striking, shaking, etc. The camera contains sensitive components which could be damaged by improper handling or storage.
- Do not let the lens remain uncapped when the camera is not in use. If the lens is not installed, do not leave the lens mount hole uncovered.
- Do not touch the surface of the lens or prism.
- Do not use strong or abrasive detergents when cleaning the camera body.
- Do not aim the camera toward the sun, no matter whether it is turned on or not.
- Do not expose the camera or Remote Control Unit (RCU) to rain or moisture, and do not try to operate the equipment in wet conditions. Do not operate the camera or RCU if it becomes wet.
- Do not operate the camera or Remote Control Unit (RCU) outdoors during a lightning storm.
- Do not use the camera in an extreme environment where high temperatures or high humidity exist.
- Do not leave the camera and Remote Control Unit (RCU) turned on when not in use. Do not unnecessarily turn the camera power on and off repeatedly. Do not block the ventilation slots.

DO'S

- Refer any servicing to qualified service personnel.
- Handle the camera with care.
- Protect the precision made lens by placing the lens cap over when the camera is not in use. If the lens is not installed, protect the surface of the prism by placing the body cap into the lens mount hole.
- Use a mild blower or lens cleaning tissue designed for coated lenses, to clean the surface of the lens or prism in the event that it should become dirty.
- Use a dry cloth to clean the camera if it is dirty. In case the dirt is hard to remove, use mild detergent and wipe gently.
- Use caution when operating the camera in the vicinity of spot lights or bright lights, as well as light reflecting objects and surfaces.
- Take immediate action if ever the camera or RCU should become wet. Turn the power off and have the unit checked by an authorized service facility.
- Follow normal safety precautions to avoid personal injury.
- Use the camera in an environment where the temperature is within -10°C - $+45^{\circ}\text{C}$ (14°F - 113°F), and the relative humidity is within 30 % - 90 %.
- Always turn the power off when the camera is not going to be used. Operate the camera and RCU only when there is adequate ventilation.

MAJOR OPERATING CONTROLS AND THEIR FUNCTIONS

<Front View>

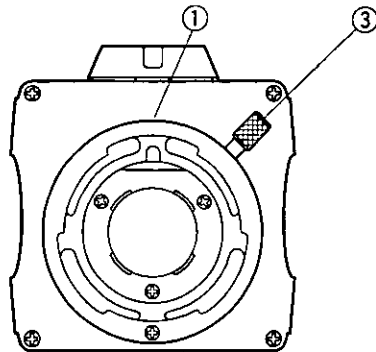

<Top View>

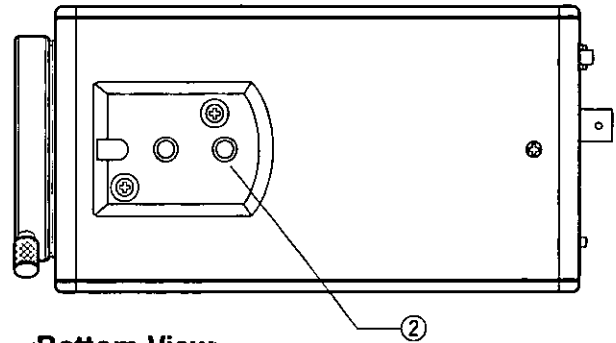

<Side View>

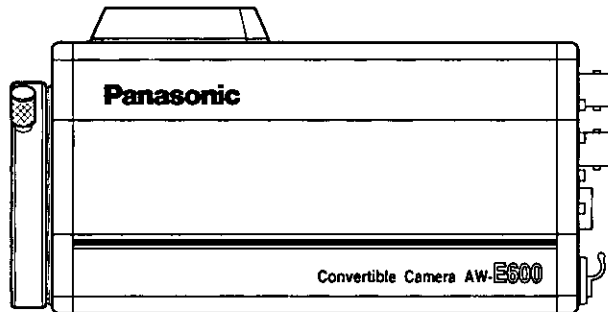

<Bottom View>

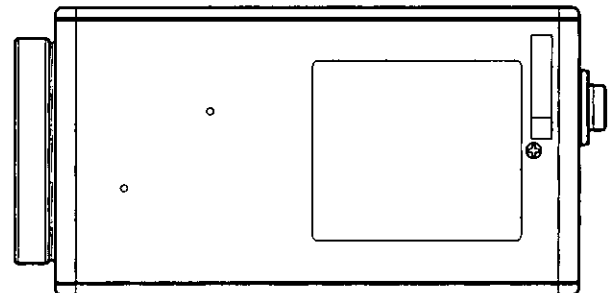

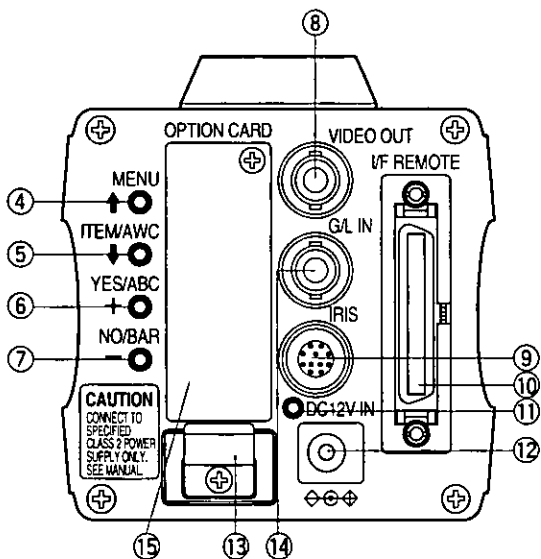

1. Lens Mount

1/2" Standard bayonet type lens or a microscope adaptor can be mounted.

2. Mounting Adaptor

A screw hole (1/4" - 20 UNC) adaptor for mounting the camera on a wall, ceiling with a mounting bracket or tripod.

3. Lens fixing ring knob

Rotate the lens fixing ring knob counterclockwise and remove the lens mount cap. Mount the lens on the camera and rotate the lens fixing ring knob clockwise in order to fix the lens securely.

4. MENU Switch (MENU/!)

A menu will appear on the monitor screen when this switch is pressed for about 5 seconds. This item can be selected by pressing the switch while the menu is on the screen.

5. ITEM/AWC Switch (ITEM/AWC/!)

The item just below can be selected by pressing this switch while the menu is on the screen. When the menu is not displayed or the camera is in shooting mode, the automatic white balance control can be set with this switch.

6. YES/ABC Switch (YES/ABC/+)

The Sub Menu for each item of the Main Menu is displayed when this switch is pressed while the Main Menu is on the screen.

While the Sub Menu is displayed, any setting can be brought up to a higher value with this switch. When the menu is not displayed or the camera is in shooting mode, the automatic black balance control can be set with this switch.

7. NO/BAR Switch (NO/BAR/-)

The item just below can be selected by pressing this switch while the Sub Menu is on the screen.

While the Sub Menu is displayed any setting can be brought down to a lower value with this switch. When the menu is not displayed or the camera is in shooting mode, the color bar and the shooting conditions are alternately indicated by pressing the switch.

8. Video Output Connector (VIDEO OUT)

A composite video signal is provided at this connector.

9. Iris Connector (IRIS)

Input terminal for lens with an iris control function.

Pin No.	Signal	Pin No.	Signal
1	Return Control	7	Iris Follow
2	Not Used	8	Auto/Remote Control
3	GND	9	Not Used
4	Auto/Manual Control	10	Not Used
5	Iris Control	11	Not Used
6	Lens Power	12	Not Used

Iris Connector (IRIS)

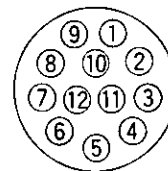

<Front View>

10. I/F Remote Connector (I/F REMOTE)

Input terminal dedicated to control signals from the optional Remote Control Box (RCB) (WV-CB700A) and the RCU (WV-RC700A, WV-RC550) and the camera pan/tilt unit (AW-PH300).

- * WV-CB700A is connected through the optional RCB cable (AW-CA50T10).
- * WV-RC700A/WV-RC550 is connected through the optional RCU cable (AW-CA50A26).
- * AW-PH300 is connected through the optional pan/tilt unit cable (AW-CA50T15).

11. Power Indicator

Red LED lamp lights to indicate that the specified DC power is supplied to the camera.

12. DC 12 V Input Connector (DC 12V IN)

12 V DC is supplied through the optional DC power supply cable (AW-CA4T1).



13. Cable Clamp

Clamp the DC Power Supply Cable (AW-CA4T1) connected to the DC 12 V Input Connector to prevent it from slipping out.

14. G/L Input Connector (G/L IN)

Signals synchronized with the reference signal are to be supplied to this connector when the camera is to be synchronized with the reference signal BB.

15. Optional Card Slot

Slot for inserting an optional card. For details, refer to the manual for optional cards.

MOUNTING

- Lenses of any make can be mounted on the camera as long as they are equipped with a 1/2" standard bayonet.
- Use the lens extension cable WV-CA12T12 (6"/15 cm) if your lens cable is too short.

1. Lens Mounting

Rotate the lens fixing ring knob counterclockwise and remove the lens mount cap. Mount the lens on the camera and rotate the lens fixing ring knob clockwise in order to fix the lens securely. Connect the camera cable to the IRIS connector on the back panel of the camera.

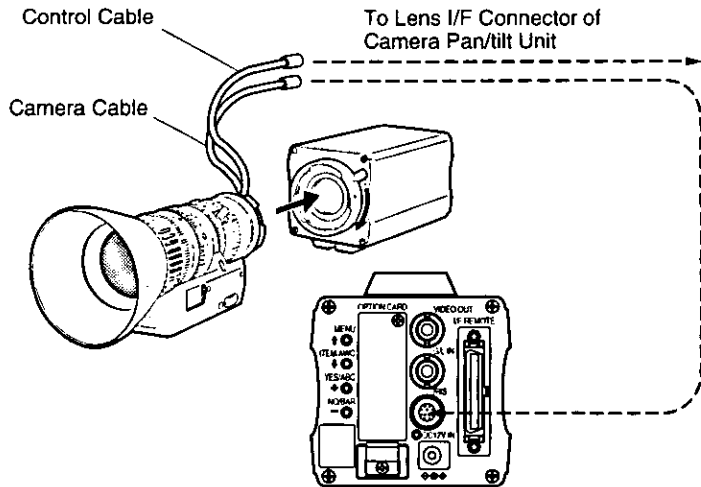

2. Camera Mounting

1. Fix the mounting adaptor to the top or bottom of the camera.

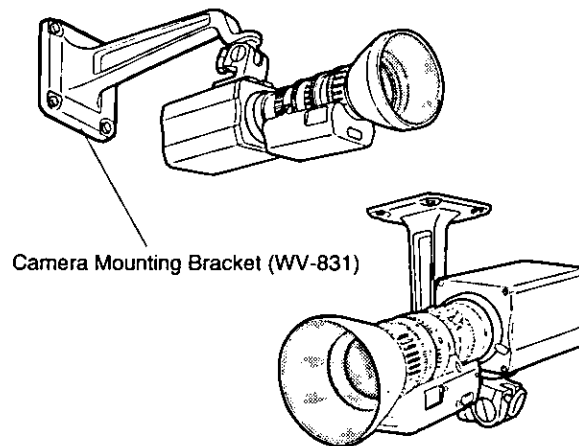
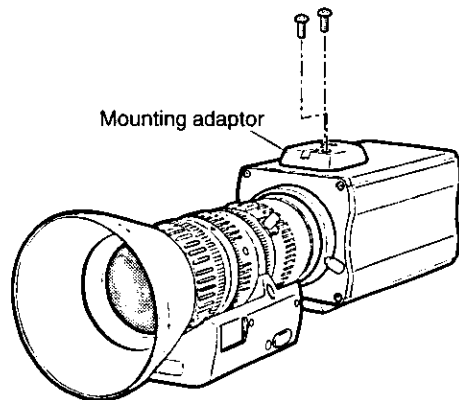

2. Fix the camera mounting base, pan/tilt unit, and tripod securely in the screw hole (1/4-20UNC) of the camera mounting adaptor.
3. If the camera cannot be securely fixed, stick the supplied rubber sheet to the mounting adaptor, then mount the camera.

FLANGE BACK ADJUSTMENT (FOR ZOOM LENS)

1. Fully open the iris by shooting a dark object. (Iris selection switch should be set to M.)
2. Loosen the flange back lock knob.
3. Aim the camera at any object over 2 meters away from the camera.
4. Set the lens to its TELE end first and adjust its focus with the focus ring.
5. Set the lens to its widest angle next and adjust its focus with the flange back adjust ring.
6. Adjust the focus ring and the flange back adjust ring alternately for the best focus within the zooming range.
Tighten the flange back lock knob upon completion of focusing.
7. Turn the iris selection switch to Position A.

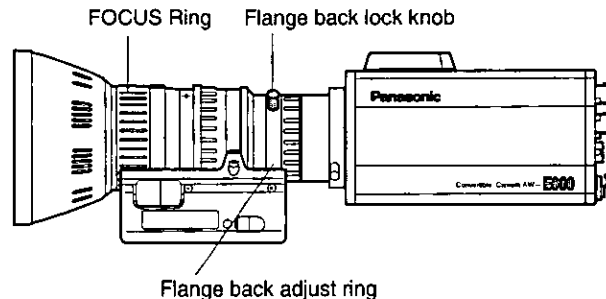

IRIS GAIN CONTROL IN A LENS

An iris gain control hole is usually provided in the front of the lens. Adjustment of the iris gain, with a screwdriver through the hole may be done as follows. (Shape and location of the hole may vary depending on the type of lens.)

1. Turn the iris selection switch to Position A (AUTO).
2. Rotate the iris gain control to the maximum gain, but in a range where no hunting or oscillating of the iris ring develops.

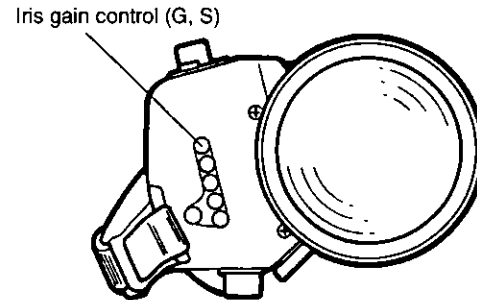

Automatic iris power zoom lens

CONNECTIONS

Caution:

The connection and installation should be done by qualified service personnel or system installers. Refer any servicing to qualified service personnel.

■ CONNECTION OF DEVICE WITH A COMPOSITE INPUT CONNECTOR

- Connection to any device which has a composite input connector, such as a video monitor or a VCR, must be made through the VIDEO OUT Connector.
- Power supply to the camera must be through the optional DC power supply Cable AW-CA4T1.
- For DC power supply, use the optional AC adaptor AW-PS505.

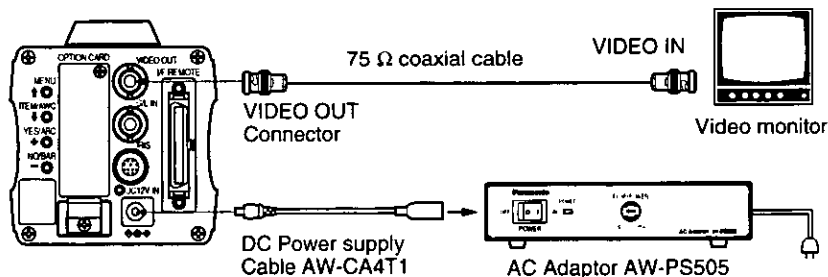

Cautions

1. Connect this to a DC 12 V class 2 power supply only.
2. To prevent fire or shock, the UL listed wire VW-1, style 1007 should be used as for the cable for DC 12 V Input Connector.

■ CONNECTION OF A REMOTE CONTROL UNIT (RCU)

Connection to the RCU (WV-RC700A,WV-RC550) is made through the optional RCU cable AW-CA50A26.

1. Turn RCU power off before connecting cables.
2. Set the cable selection switch of the RCU to MULTI (in case of using the WV-RC700A)
3. Connect the 50-pin connector of the RCU cable to the I/F REMOTE Connector of the camera.
4. Turn RCU power on and the power indicator lamp will light. The camera can now be remote controlled by the RCU.

Notes:

- The maximum extension distance between the camera and WV-RC700A is 300 m. The maximum extension distance between the camera and WV-RC500 is 100 m.
- Use the following options for cable extension.

Studio Cable	WV-CA26U15 (15 m/50 ft)
	WV-CA26U30 (30 m/100 ft)
	WV-CA26U100 (100 m/330 ft)

Cable Joint Adaptor
WV-CA26T26

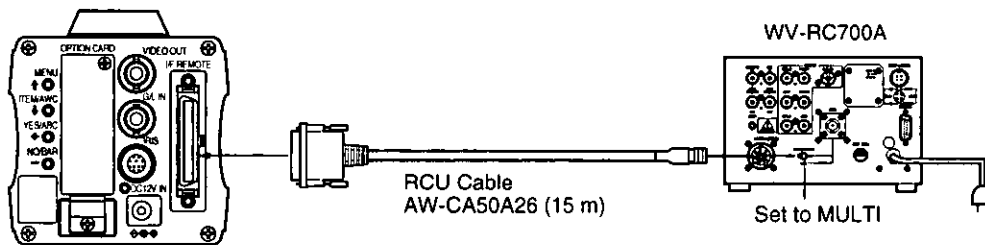

■ CONNECTION OF A REMOTE CONTROL BOX (RCB)

The RCB (WV-CB700A) and the camera must be connected with the optional RCB cable AW-CA50T10.

1. Turn RCB power off before connecting cables.
2. Connect the 50-pin connector of the RCB cable to I/F REMOTE connector of the camera. The 10-pin connector must be connected to the RCB.

3. Turn RCB power on and the camera can be controlled remotely by the RCB.

Notes:

- The monitor output signals of the RCB attenuate and deteriorate with cable length. It is recommended that the signals from the monitor output be used for monitoring purposes only.
- No gen-lock signal is available from the RCB.

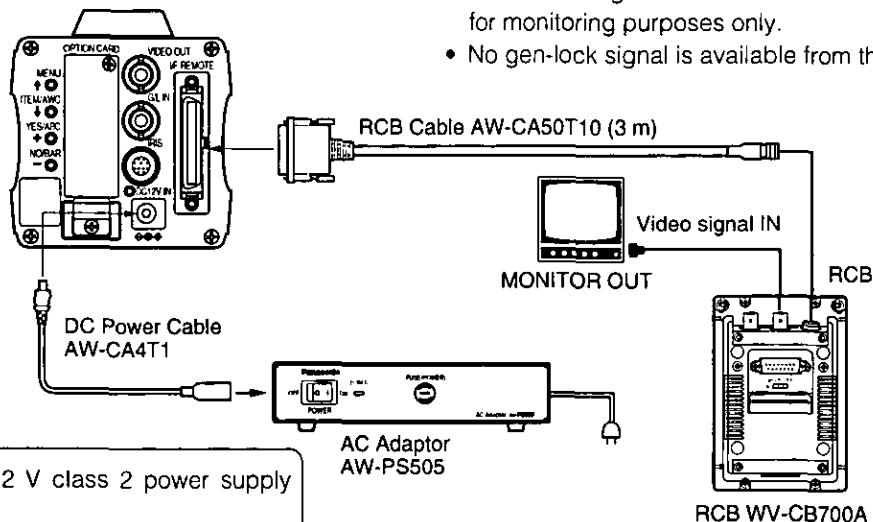

Cautions

1. Connect this to a DC 12 V class 2 power supply only.
2. To prevent fire or shock, the UL listed wire VW-1, style 1007 should be used as for the cable for DC 12 V Input Connector.

■ CONNECTION OF DEVICES WITH CAMERA PAN/TILT CONTROL SYSTEM

- To connect the pan/tilt unit to the camera, use the pan/tilt unit cable AW-CA50T15.
 - Power is supplied from the pan/tilt unit.
1. Before connecting them, press the power switch on the pan/tilt unit AC adaptor and the ON/OFF switch on the hybrid control panel in the OFF position, respectively.
 2. Fix the camera securely to the pan/tilt unit using the mounting adaptor.
 3. Connect the 50-pin end of the pan/tilt unit cable to the I/F Remote connector on the camera. Connect the 15-pin end of the cable to the pan/tilt unit.
 4. Connect the pan/tilt unit to the hybrid control panel with the 10BASE-T cable and coaxial cable. For details, refer to the manual for the hybrid control panel.
 5. First switch on the pan/tilt unit AC adaptor, then press the ON/OFF switch on the hybrid control panel in the ON position. The camera and pan/tilt unit can now be controlled from the hybrid control panel.

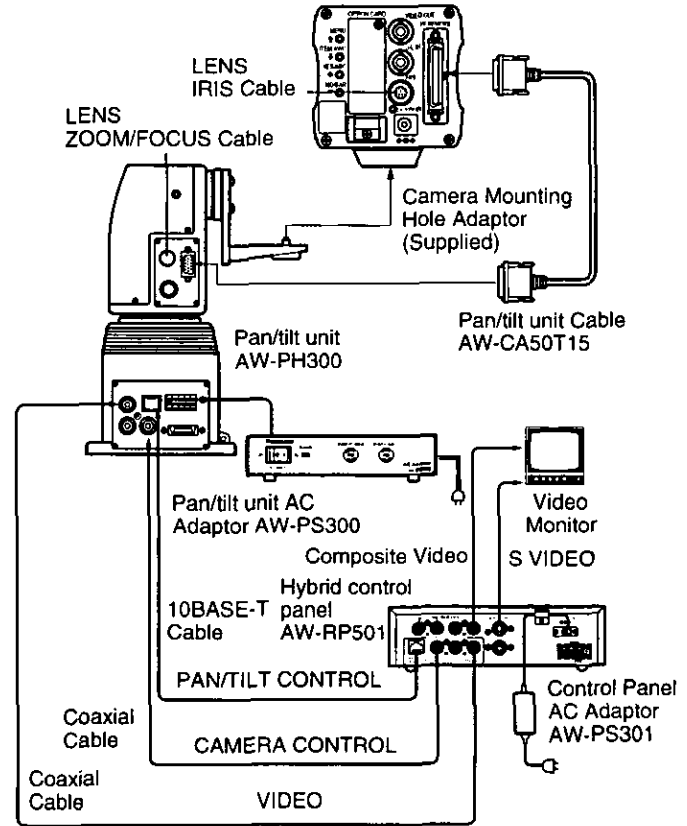

■ CONNECTION WITH MULTIPLE CAMERAS (COLOR LOCK MODE)

- An example of connection for VBS/BB input (Color lock mode).
- One of the multiple cameras is used as the source of reference signals.
- Supply a synchronizing signal (BB) to the G/L Input Connectors of each cameras.
- Do not switch off the camera used for supplying the reference signals.
- Adjust the SC-phase and H-phase at the Video Output Connector.

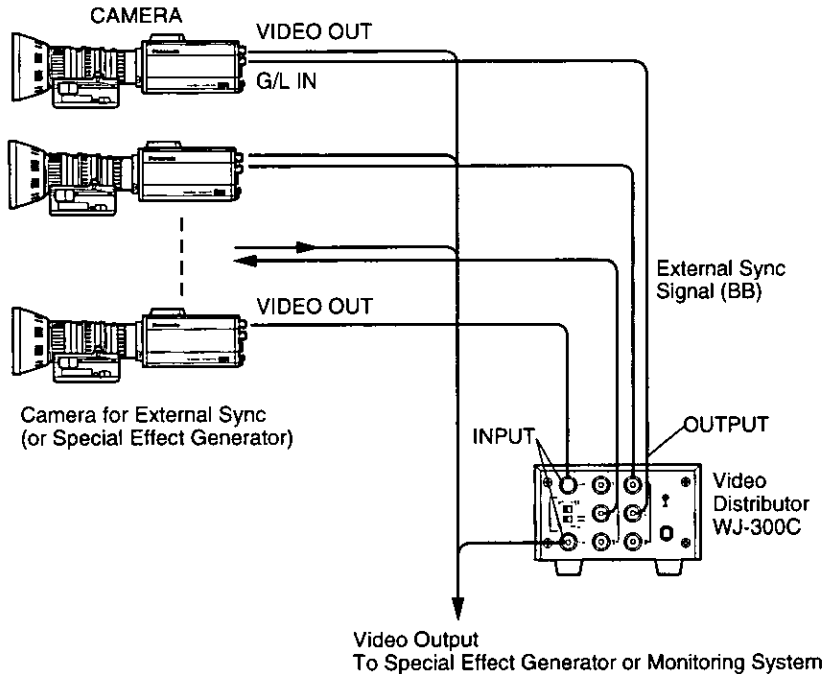

■ CONNECTION OF COMPUTER

The system shown here can remotely control this camera by using a computer.
The software and the cable for RS-232C required for this operation should be obtained locally.
Please contact qualified service personnel for this software.

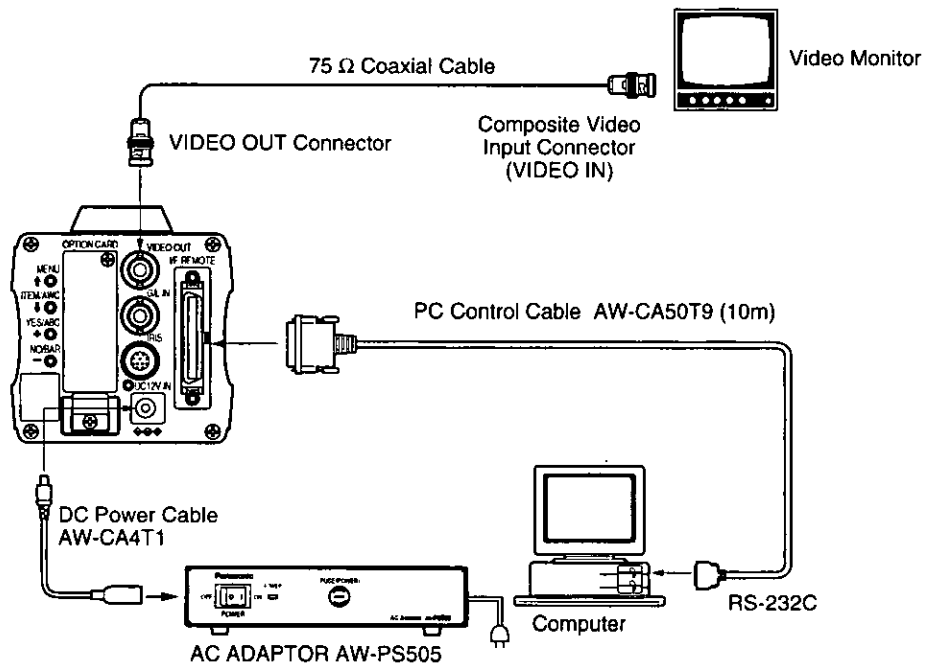

ADJUSTMENT

Color temperature and adjustment of white balance

When carbon is burnt, it develops various colors of light depending on the temperature. Natural light can be specified by color temperature referring to the color developed when carbon is burnt.

The light of 3 200K (K=Kelvin, -273C equals to absolute zero temperature 0K) represents the same value (color) as what develops when carbon is burnt at 3 200K ($2\ 927\text{C}$). The relationship between the color temperature of the light source and weather condition is indicated in the right figure. Let's study the difference of shooting an indoor object from shooting one outdoors. Studios are usually lighted with incandescent lamps and the color temperature of a white object in a studio is around 3 000K. The color temperature of a white object outdoors is around 6 500 K. The former may look a little yellowish while the latter appears somewhat bluish when they are shot by a camera. However, the human eye does not recognize color differences among these objects even under different ambient lighting conditions, because of their adaptability to light. The video camera reproduces color differences with high fidelity and the color of an object somewhat different from what appears to the human eye.

Therefore, there is a need to adjust the white balance in order to correct differences between color temperatures.

NOTE: Color temperature outdoors may vary depending on weather conditions.

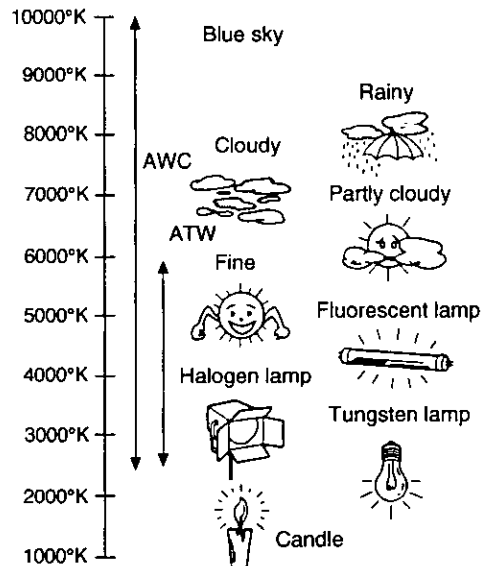

■ AUTOMATIC WHITE BALANCE CONTROL (AWC)

There are two white balance memories, "AWC A" or "AWC B" for two different light sources color temperatures, with the automatic white balance setting. Then, when the two different light sources are encountered, you may operate the camera properly by simply change the white balance mode to either AWC A or AWC B. There is no need to readjust the camera to the ambient conditions.

* The preset conditions will be renewed whenever you input new conditions.

1. Turn the white balance selection switch to either "AWC A" or "AWC B" of RCU or select the white balance mode either AWC A or AWC B by menu.
2. Aim the camera at a white object (a white wall or a white handkerchief) and zoom in to enlarge the image as much as possible.

[ADJUSTMENT by CAMERA]

3. In normal shooting mode:
Press the Item/AWC switch for over 2 second.

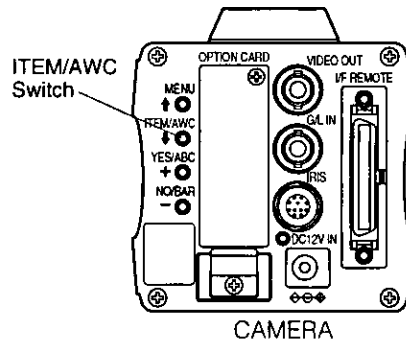

[ADJUSTMENT with the RCU (RCB, Hybrid control panel)]

4. When the AUTO set switch is turned to AWC, the white balance will be automatically set. While the system is being set, auto warning indicator (LED) blinks and it goes out when the white balance setting is completed. If the lamp remains lit, the setting must be tried again.

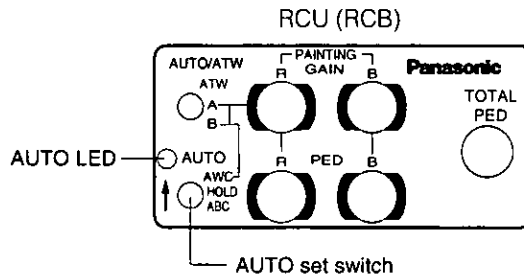

Notes:

- For white balance setting aim the camera at a white object and try to position it in the center of the monitor screen. The object must appear in over 10 % of the total monitor screen area. Try to avoid overly bright objects in the scene.
- White balance may not be correctly set if the lighting of the object is too weak.

The white object must occupy over 10 % of the monitor screen area.

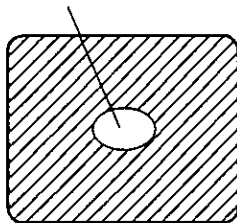

- Since the camera has a built-in memory, the set white balance will remain in the memory even if power is turned off. Therefore, it is not necessary to reset the white balance if the color temperature of those objects remains unchanged. However, it must be reset if the color temperature changes, such as when you move from indoors to outside, or vice versa.
- When the camera is used without a RCU or RCB red/blue gain adjustment of painting setting will be automatically reset to ± 0 after setting the white balance. (painting setting in only USER MODE.)

■ AUTOMATIC TRACKING WHITE BALANCE SETTING (ATW)

White balance will be automatically set to continuously match changes of light source and color temperature while the white balance setting is set to ATW.

Note: White balance may not be accurately set if there is no white object in the scene being shot.

■ MANUAL WHITE BALANCE SETTING

[ADJUSTMENT by CAMERA]

Manual setting is possible in USER MODE only.

1. Select the white balance mode either AWC A or AWC B by menu.
2. Aim the camera at a large white object. Press the Item/AWC switch for over 2 second.
3. Adjust the red gain/blue gain control in the PAINTING item of Color Set sub menu of USER MODE until the carrier wave of the white portion of the video signal is at the minimum width or the white object in the monitor screen appears pure white. (Use an oscilloscope or a waveform monitor for precise adjustment.)

[ADJUSTMENT with the RCU (RCB)]

After AWC setting, adjust the R/B GAIN controller in the same way as described in Step 3 above.

Minimize the carrier wave using the red & blue gain controls

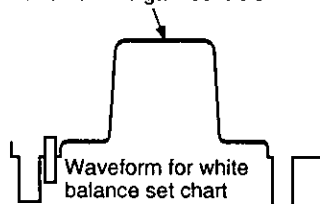

■ RESET TO 3 200K OR 5 600K WHITE BALANCE

When the white balance setting is set to either "P SET 3 200K" or "P SET 5 600K" the white balance will be automatically set to the color temperature 3 200K or 5 600K, respectively.

■ BLACK BALANCE ADJUSTMENT

- Close the lens.
If the motor drive lens is controlled from the camera, the lens is automatically closed when the black balance is adjusted.
- When the camera is used without a RCU or RCB, R/B pedestal adjustment of painting setting will be automatically reset to ± 0 after setting the black balance. (painting setting in only USER MODE.)

[ADJUSTMENT by CAMERA]

Press the YES/ABC Switch for over 2 seconds and the black balance will be set automatically in 10 seconds.

In user mode, black balance fine adjustment can be performed with the red pedestal/blue pedestal setting after setting the black balance.

[ADJUSTMENT with the RCU (RCB, Hybrid control panel)]

Set the AUTO set switch to ABC and the black balance will be automatically set. While the system is being set, the auto warning indicator (LED) blinks and it goes out when the black balance setting is completed. If the lamp remains lit, ABC should be tried again.

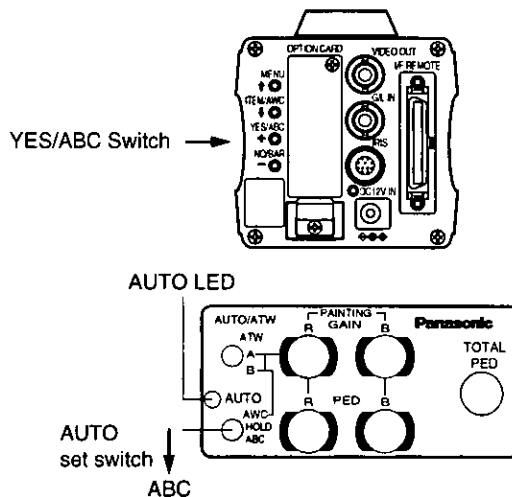

■ TOTAL PEDESTAL LEVEL ADJUSTMENT

(Use an oscilloscope or a waveform monitor for this adjustment.)

This step is to adjust the black levels (pedestal levels) of two or more cameras to be the same.

[ADJUSTMENT by CAMERA]

1. Close the lens.
2. Select Pedestal item in the brightness setting Sub Menu (Select [Pedestal] in the [Iris, Shutter, Gain Set] sub menu in USER MODE.)
3. Set the pedestal level to 5 IRE (0.035 V) with the YES/ABC switch or the NO/BAR switch.

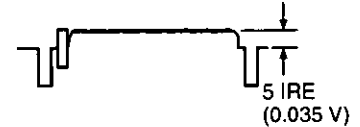
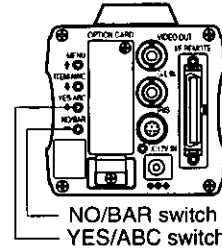
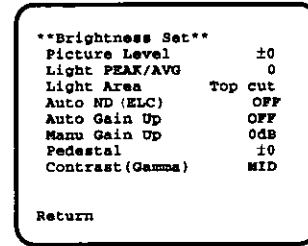

[ADJUSTMENT with RCU (RCB, Hybrid control panel)]

Adjust the pedestal level to 5 IRE with the total pedestal adjustment.

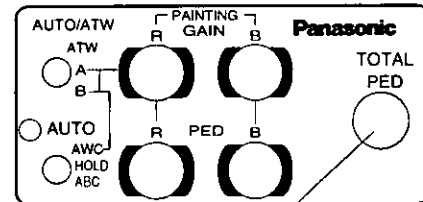

TOTAL PEDESTAL

■ GEN-LOCK ADJUSTMENT

Phase adjustments must be performed with the camera or the RCU (RCB) when external synchronizing signals are supplied to the system in cases where multiple cameras are used or peripheral devices are connected.

● HORIZONTAL PHASE CONTROL

Observe the waveform of the external synchronizing input signal (black burst signal) and video output signal on a two-channel oscilloscope. Then match the horizontal phase of both signals by adjusting them with the cameras or RCU's horizontal phase control.

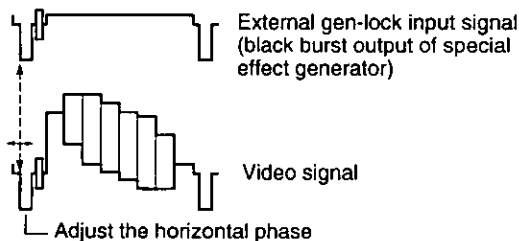

[ADJUSTMENT by CAMERA]

1. Press the NO/BAR switch for over 5 seconds to display the color bar.
2. Select [G/L. Color Bar Set] on the main menu, then select [H PHASE] on the submenu.
3. Adjust the horizontal phase with the YES/ABC and NO/BAR switch.

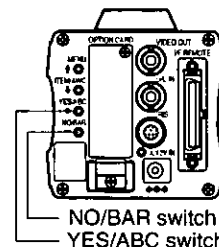
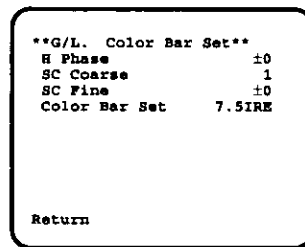

[ADJUSTMENT with RCU (RCB, Hybrid control panel)]

Use the horizontal phase control.

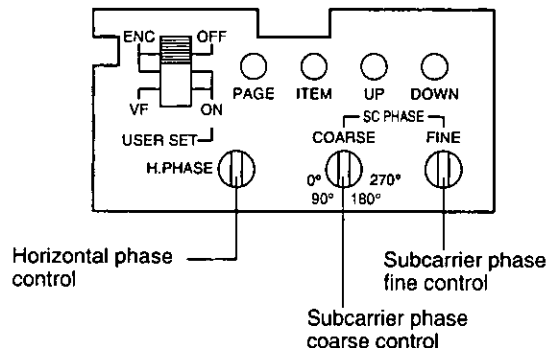

● COLOR PHASE ADJUSTMENT

Supply the output signal (split color bar) from the color special effect generator to a color monitor or vectorscope. Adjust the color phase of the camera.

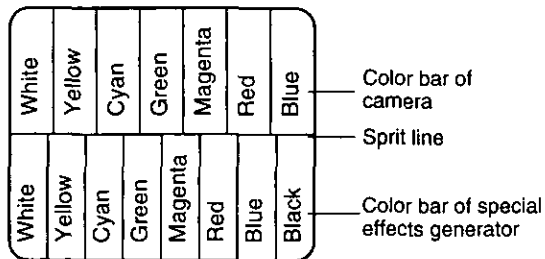

[ADJUSTMENT by CAMERA]

1. Press the NO/BAR switch for over 5 seconds for the color bar mode.
2. Select [G/L. Color Bar Set] on the main menu, then select [SC Coarse] on the sub menu.
3. Make coarse adjustment with the YES/ABC switch and the NO/BAR switch.
4. Select [SC Fine] on the sub menu. Perform fine adjustment with the YES/ABC switch and the NO/BAR switch.

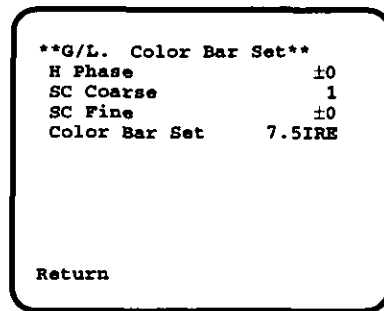

[ADJUSTMENT with RCU (RCB, Hybrid control panel)]

Use the subcarrier phase coarse adjustment control and subcarrier phase fine control.

* It is recommended that a vectorscope be used for maximum accuracy in color phase adjustment.

USE MODE SETTING

■ Use Mode Setting

The camera has four use modes, and various functions for four use modes have been preset.

Functions can be set as best suited to each use mode.

- Halogen mode
Suited to indoor shooting, such as at weddings, parties, lecture meetings, events, etc.
Settings can be changed using a simple menu.
- Fluorescent mode
Suited to indoor shooting under fluorescent lighting.
Settings can be changed using a simple menu.
- Outdoor mode
Suited to outdoor shooting.
Settings can be changed using a simple menu.
- User mode
Settings can be changed using a detail menu.

■ SETTING BY CAMERA

1. Turn the camera on while keeping the MENU switch depressed.
The use mode setting menu shown at right appears on the monitor screen and one of the use mode blinks.

2. Press the MENU switch, ITEM/AWC switch, or NO/BAR switch to let the desired use mode blink.
MENU switch (↑): The blinking item moves up by one.
ITEM/AWC switch (↓), NO/BAR switch (-): The blinking item moves down by one.

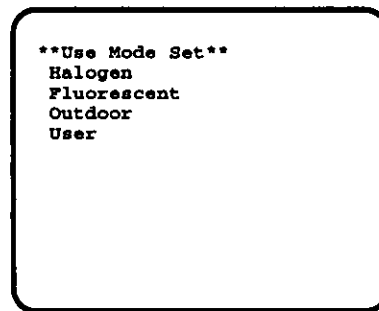

3. Press the YES/ABC switch.
The blinking use mode comes into effect. After the use mode setting menu is shown for about 5 seconds, the camera returns to be ready for operation. Then, the camera operates in the selected use mode.

■ SETTING BY RCU (RCB) OR HYBRID CONTROL PANEL

An operation mode is selected depending on the position of the scene file switch.

Operation mode	Scene File Switch Position of RCU (RCB)	Scene File Switch Position of Hybrid control panel
Halogen Mode	1	1
Fluorescent Mode	2	2
Outdoor Mode	3	3
User's Mode	USER SET	4

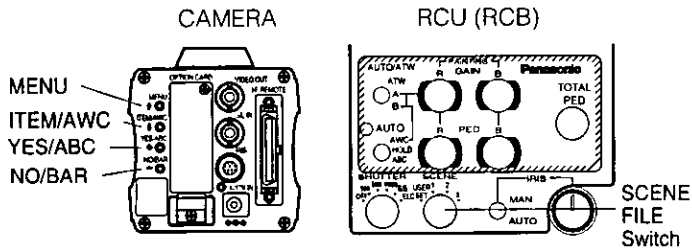

Hybrid Control Panel

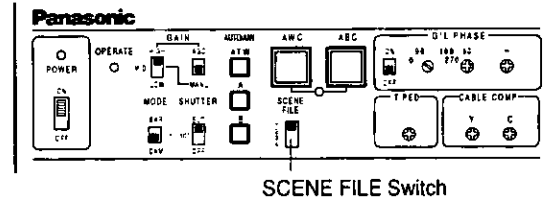

MENU ITEM SETTING

■ MENU ITEM SETTING

- Each of the four use modes of the camera has a main menu. (Shown at right)
- Each item of the main menu has a submenu, which consists of several settings.
- These settings have been preset to the optimum values to suit each use mode, and can be changed to suit actual shooting conditions.
- They can be set from the camera and RCU (RCB). They can also be set from the hybrid control panel using the switches, but the setting items are limited because the menu is not shown.

Notes:

- Composite signals are output from the video output regardless of the position ENC/VF of the RCU (RCB) user set switch.
- [End] is displayed only in setting from the camera alone.

● MAIN MENU SCREEN

Main Menu of Halogen,
Fluorescent, Outdoor Mode

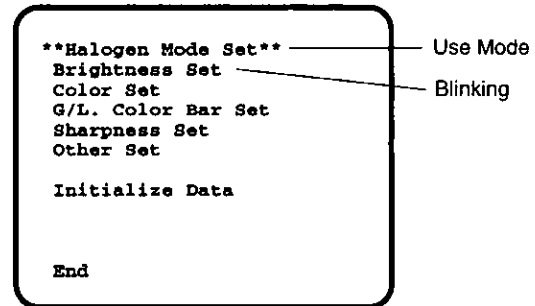

Main Menu of User Mode

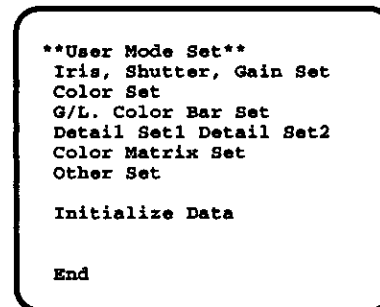

■ SETTING

1. From the camera alone:

Keep the MENU switch depressed for 5 seconds or more.

From RCU (RCB):

Set the user set switch in the pocket to the ON position.

The main menu appears on the monitor screen.

2. Each time the MENU switch (↑), ITEM/AWC switch (↓), or NO/BAR switch (-) is pressed, the blinking item moves up or down.
3. When the YES/ABC switch is pressed after selecting the desired item to blink, the submenu for the selected item appears on the screen.
4. Select the desired item to be changed in its settings using the MENU switch (↑) and ITEM/AWC switch (↓).
5. Press the YES/ABC switch (+) or NO/BAR switch (-) to change the settings.
6. Select [Return] using the MENU switch and ITEM/AWC switch, then press the YES/ABC switch to return to the main menu.
7. After changing the settings, take the following steps.

Camera alone: Select [End] using the MENU switch and ITEM/AWC switch and press the YES/ABC switch.

RCU (RCB): Set the user set switch in the pocket to the OFF position.

The camera will now operate according to the new settings.

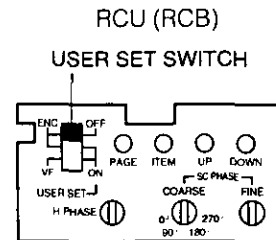
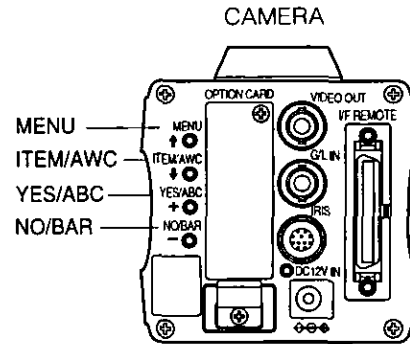

■ SUB MENU (Halogen Mode, Fluorescent Mode, Outdoor Mode)

****Brightness Set****

1	Picture Level	±0
2	Light PEAK/AVG	0
3	Light Area	Top cut
4	Auto ND (ELC)	(OFF)
5	Auto Gain Up	(OFF)
6	Manu Gain Up	(0dB)
7	Pedestal	(±0)
8	Contrast (Gamma)	MID

Return

****G/L. Color Bar Set****

12	H Phase	±0
13	SC Coarse	(1)
14	SC Fine	(±0)
15	Color Bar Set	(7.5IRE)

Return

****Other Set****

22	Shutter Speed	(OFF)
23	Syncro Scan	---
24	V Resolution	Normal
25	Baud Rate	9600bps
26	Nega/Posi	Posi

Return

****Color Set****

9	Chroma Level	±0
10	Flesh Tone	±0
11	White Bal	(AWC A)
12	Highlight Chroma	OFF

Return

****Sharpness (DTL) Set****

17	DTL Select	Sharpness
18	Level	(HIGH)
19	Noise Suppress	OFF
20	Clean DNR	OFF
21	DTL Flesh Tone	MID

Return

- Settings enclosed in parentheses can be set with the RCU (RCB) switch or VR in RCU (RCB) mode.
- To return to the initial settings, refer to page 46.

■ Setting and Changing of the Setting (Halogen Mode, Fluorescent Mode, Outdoor Mode)

① Video Level Adjustment

[Picture Level: -50 - +50]

Convergence level of AUTO IRIS/AUTO GAIN UP/AUTO ND (ELC) can be adjusted.

② Detecting Ratio Adjustment [Light PEAK/AVG: P50 - A50]

The ratio of AUTO IRIS/AUTO GAIN UP/AUTO ND (ELC) detected peak to average can be adjusted within a predetermined range.

③ Photometric Measurement Method Setting [Light Area: All, Center, Top cut, BTM cut, R/L cut]

A photometric measurement method can be selected for AUTO IRIS/AUTO GAIN UP/AUTO ND (ELC).

All: All the screen area is measured.

Center: The screen is measured mainly in the center area, about one-third of both the top and bottom and one-third of both the right and left portions of the screen are excluded from measurement.

Top cut: About one-third of the top part of the screen is excluded from measurement.

BTM cut: About one-third of the bottom portion of the screen is excluded from measurement.

R/L cut: About one-third of both the right and left portions of the screen are excluded from measurement.

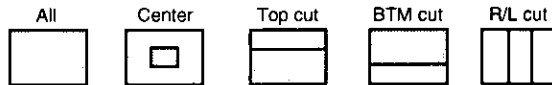

④ Auto ND (ELC) Setting [Auto ND (ELC): ON/OFF]

ON: The electronic shutter is controlled to automatically adjust the luminance.

OFF: Luminance is not automatically adjusted by the electronic shutter.

Notes

- ON is automatically selected when the electronic shutter ② on the submenu [Other Set] is set to [Auto ND]. OFF is selected when other than [Auto ND] is selected.
- ON is selected when the SHUTTER switch is set to [ELC] in RCU (RCB) mode, and OFF is selected when it is set to other than [ELC].

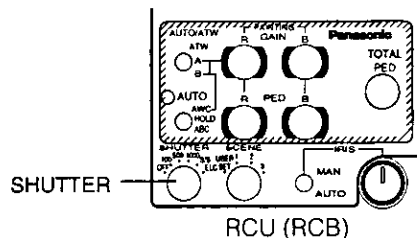

5 Auto Gain Up Control Setting [Auto Gain Up: OFF/ LOW/HIGH]

LOW: The Auto Gain Up control with a maximum gain increase of about 18 dB adjust the luminance automatically.

HIGH: The Auto Gain Up control with a maximum gain increase of about 30 dB operates. If the luminance is still insufficient, the Night Eye also operates to adjust the luminance automatically.

OFF: No auto gain up takes place. (Gain can be increased manually.)

6 Manual Gain Up Control Setting [Manu Gain Up: 0 dB - 30 dB / N/Eye L / N/Eye H]

Manual setting is possible only when the Auto Gain Up control is in the OFF position.

0 dB: 0 dB should be selected in normal cases.

1 dB - 30 dB: Use this range if sufficient video output cannot be obtained even when the lens iris is opened in shooting dark scenes.

N/Eye L / N/Eye H (Night Eye L/H): Use this mode if sufficient video output cannot be obtained even if 30 dB gain up should be selected.

Night Eye can be selected to any of two (L or H) levels.

Notes

- In case of settings on the camera alone or when the iris switch on the RCU (RCB) is at [AUTO], the Auto Gain Up control may not operate if the lens iris switch is in the manual position.
- When the AGC switch on the hybrid control panel is set to AGC, the Auto Gain Up control operates in the HIGH position.

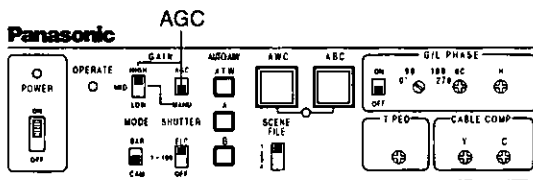

Hybrid Control Panel

Notes

- Only 0 dB, 9 dB, or 18 dB can be selected in case of using the RCU (RCB).
- 0 dB when the manual GAIN switch on the hybrid control panel is at LOW, 9 dB when it is at MID, or 18 dB when it is at HIGH.

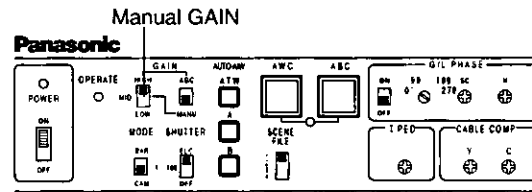

Hybrid Control Panel

- ⑦ **Black Level Setting [Pedestal: -30 - +30]**
The black level (pedestal) of the luminance (Y) signal can be set. Used in adjusting the black levels of two or more cameras.

- ⑧ **Contrast Adjustment [Contrast (Gamma): LOW/MID/HIGH]**
Contrast can be adjusted to any of three levels.

- ⑨ **Chroma Level Adjustment [Chroma Level: -3 - +3]**
Chroma Level can be decreased or increased to any of three levels each.

- ⑩ **Skin Color Adjustment [Flesh Tone: -3 - +3]**
Skin color can be decreased or increased to any of three levels each.

- ⑪ **White Balance Setting [White Bal: ATW/AWC A/ AWC B/P SET 3 200K/P SET 5 600K]**
ATW: The white balance is automatically adjusted to be always right.
AWC A, AWC B: Once the white balance is adjusted with the ITEM/AWC switch on the back of the camera, it is no longer necessary to set the white balance again if you simply select AWC A or AWC B, provided that the camera is used under the same conditions.

Fine color adjustment can be made after setting AWC by red/blue gain adjustment in user mode or from the RCU (RCB).

P SET 3 200K: The white balance is adjusted to 3 200K illumination.

P SET 5 600K: The white balance is adjusted to 5 600K illumination.

Note

Neither P SET 3 200K nor P SET 5 600K can be set from the RCU (RCB) or the hybrid control panel.

- ⑫ **Highlight Chroma Setting [Highlight Chroma: OFF/LOW/HIGH]**
At LOW or HIGH, the color dynamic range widens to prevent highlighted white portions from suppression.
- ⑬ **Horizontal Phase Adjustment [H Phase: -206 - +49]**
Horizontal phase can be adjusted when a genlock signal is supplied.
- ⑭ **Sub Carrier Phase Coarse Adjustment [SC Coarse: 1/2/3/4]**
Coarse adjustment of subcarrier phase can be made when a genlock signal is supplied.

15 Subcarrier Phase Fine Adjustment [SC Fine: -511 - +511]

Fine adjustment of subcarrier phase can be made when a genlock signal is supplied.

16 Color Bar Setup Setting [Color Bar Set: 0.0IRE/7.5IRE]

The setup level of color bar can be adjusted.

17 Detail Select Setting [DTL Select: Sharpness/ Super DTL]

If contour correction is not sufficient at the Sharpness position when Detail Level setting **18** is set to LOW or HIGH, select the Super DTL position.

Note

Neither Sharpness nor Super DTL is valid for contour correction if Detail Level setting **18** is in the OFF position.

18 Detail Level Setting [Level: OFF/LOW/HIGH]

Detail level can be adjusted when Detail Select setting **17** is at Sharpness. Super DTL level can be adjusted when it is at Super DTL.

In case of using the RCU (RCB), the above can be adjusted with the contour correction switch (DTL).

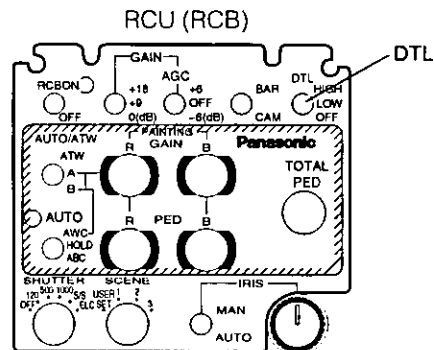

19 Noise Suppress Level Setting [Noise Suppress: OFF/LOW/HIGH]

Screen noise can be reduced when Detail Level setting **18** is at HIGH or LOW.

20 Clean DNR Setting [Clean DNR: OFF/LOW/HIGH]

Clean DNR effect can be selected.

21 Detail Flesh Tone Level Setting [DTL Flesh Tone: LOW/MID/HIGH]

- LOW:** Skin color coarseness is suppressed.
- MID:** Standard
- HIGH:** Skin color is emphasized.

22 Electronic Shutter Setting [Shutter Speed: OFF/ 1/100 to 1/10 000 / S/Scan / Auto ND]

OFF: Electronic shutter is turned off.

1/100, 1/250, 1/500, 1/1 000, 1/2 000, 1/4 000, 1/10 000:

Electronic shutter operates at one of these speeds as selected.

S/Scan (Synchro Scan): Electronic shutter operates at the speed set with the electronic shutter synchro-scan setting 23.

Auto ND: Electronic shutter is controlled to automatically adjust the luminance. (ELC)

Notes

- In case of using the RCU (RCB), none of the shutter speeds-1/250, 1/2 000, 1/4 000, and 1/10 000 can be selected.
- In case of using the hybrid control panel, only OFF, 1/100, or Auto ND (ELC) can be selected.
- If the lens iris switch is at M (Manual) when operating the camera alone or when the iris switch on the RCU (RCB) is at AUTO, Auto ND may not function. Set the lens iris switch to A (Auto).
- Flickering may increase at Auto ND under fluorescent lights.
- Auto ND is automatically selected if Auto ND (ELC) setting 4 is set to ON.

23 Electronic Shutter Synchro-Scan Setting [Synchro Scan: 60.34 Hz - 15.75 kHz]

This setting is possible only when Electronic Shutter setting 22 is at S/Scan.

Horizontal bar noise can be reduced by synchro-scan adjustment in shooting workstation scenes, for example.

- * For luminance settings at each shutter speed and synchro-scan shutter speed, refer to the table below.

Shutter Speed	Synchro-scan	Required luminance ratio
OFF	—	1
1/100	99.68 Hz	2
1/250	250.0 Hz	4
1/500	492.2 Hz	8
1/1 000	984.4 Hz	16
1/2 000	1.969 kHz	32
1/4 000	3.938 kHz	64
1/10 000	7.875 kHz	160

24 CCD Read Out Mode Setting [V Resolution: Normal/Fine]

Normal: Normal image. (CCD storage will be by field storage.)

Fine: Vertical resolution increases. (Vertical resolution is raised without increasing residual images by frame storage and electronic shutter.

Normal is recommended for general use because sensitivity will decrease at the Fine setting.

25 **PC Control Access Speed Setting [Baud Rate:
1 200 bps/2 400 bps/4 800 bps/9 600 bps]**

Select a communication speed in controlling the camera from the computer.

26 **Negative/Positive Selection
[Nega/Posi: Posi/Nega]**

Posi: Normal image

Nega: Image is shown reversed in darkness and color.

Note

When an option card is added, only the composite output and Y/C output will be reproduced in negative image.

■ Sub Menu (User Mode)

Iris, Shutter, Gain Set		
27	Picture Level	±0
28	Light PEAK/AVG	0
29	Light Area	Top cut
30	Auto Iris Adjust	OFF
31	Shutter Mode	(Step)
32	Step	(OFF)
33	Syncro Scan	---
34	Field/Frame	Field
35	Gain	(0dB)
36	Pedestal	(±0)
37	Return	

Detail Set1		
46	Detail	(HIGH)
47	H Detail Level H	+11
	V Detail Level H	+12
	H Detail Level L	+7
	V Detail Level L	+6
48	Detail Band	2
49	Noise Suppress	3
50	Level Dependent	0%
51	Dark Detail	0
52	Return	

Color Matrix Set		
53	Matrix(R-G)	±0
	Matrix(R-B)	±0
	Matrix(G-R)	±0
	Matrix(G-B)	±0
	Matrix(B-R)	±0
	Matrix(B-G)	±0
54	Return	

Color Set		
37	Chroma Level	±0
38	White Bal	(AWC A)
39	Highlight Chroma	OFF
40	Painting	
	R Gain	(±0)
	B Gain	(±0)
	R Pedestal	(±0)
	B Pedestal	(±0)
41	2D LPF	OFF
42	Return	

Detail Set2		
37	Chroma Detail	0
38	DTL Flesh Tone	MID
39	Corner Detail	OFF
40	Precision Detail	OFF
41	Return	

Other Set		
37	Gamma	0.45
38	Knee Point	88%
39	White Clip	110%
40	Flare R	0
	Flare G	0
41	Flare B	0
42	Black Stretch	OFF
43	Clean DNR	OFF
44	Baud Rate	9600bps
45	Nega/Posi	Posi
46	Return	

G/L. Color Bar Set		
42	H Phase	(±0)
43	SC Coarse	(1)
44	SC Fine	(±0)
45	Color Bar Set	7.5IRE
46	Return	

- Settings enclosed in parentheses can be set with the RCU (RCB) switch or VR in RCU (RCB) mode.
- To return to the initial settings, refer to page 46.

■ Setting and Changing of the Setting Items (User Mode)

27 Video Level Adjustment [Picture Level: -50 - +50]

Convergence level of AUTO IRIS/AGC/ELC can be adjusted.

28 Detecting Ratio Adjustment [Light PEAK/AVG: P50 - A50]

The ratio of AUTO IRIS/AGC/ELC detected peak to average can be adjusted within a range.

29 Photometric Measurement Method Setting [Light Area: All, Center, Top cut, BTM cut, R/L cut]

A photometric measurement method can be selected for AUTO IRIS/AGC/ELC.

All: All the screen area is measured.

Center: The screen is measured mainly in the center area, about one-third of both the top and bottom and one-third of both the right and left portions of the screen are excluded from measurement.

Top cut: About one-third of the top portion of the screen is excluded from measurement.

BTM cut: About one-third of the bottom portion of the screen is excluded from measurement.

R/L cut: About one-third of both the right and left portions of the screen are excluded from measurement.

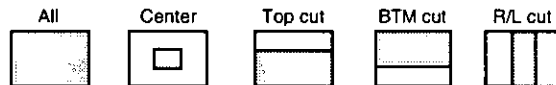

30 Auto Iris Level Fine Adjustment [Auto Iris Adjust: ON/OFF]

ON: Fine adjustment of auto iris convergence level can be made with the iris control when the iris switch on the RCU (RCB) or on the hybrid control panel is in the AUTO position.

OFF: The iris control is invalid when the iris switch on the RCU (RCB) or on the hybrid control panel is in the AUTO position.

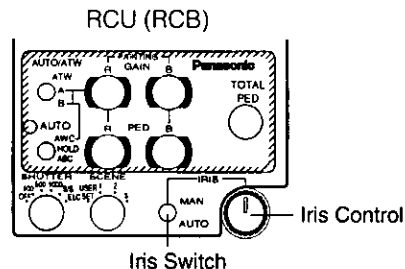

31 Electronic Shutter Mode Setting [Shutter Mode: Step/ ELC/ S/Scan]

Step: Electronic shutter operates at the speed selected by the Electronic Shutter Step Setting

32.

ELC: Electronic shutter is controlled to automatically adjust the luminance.

S/Scan (Synchro Scan): Electronic shutter operates at the speed selected in Electronic Shutter Synchro-Scan Setting 33.

Note

If Frame 1 is selected in CCD Read Out Mode Setting 34, Electronic Shutter Mode Setting cannot be added.

32 Electronic Shutter Step Setting

[Step: OFF/1/100 - 1/10 000]

This setting is possible only when Step is selected in Electronic Shutter Mode Setting 31.

OFF: Electronic shutter is turned off.

1/100, 1/250, 1/500, 1/1 000, 1/2 000, 1/4 000,

1/10 000: Electronic shutter operates at one of these speeds as selected.

Notes

- In case of using the RCU (RCB), none of the shutter speeds—1/250, 1/2 000, 1/4 000, and 1/10 000 can be selected.
- In case of using the hybrid control panel, only OFF, 1/100, or ELC can be selected.
- If the lens iris switch is at M (Manual) when operating the camera alone or when the iris switch on the RCU (RCB) is at AUTO, ELC may not function. Set the lens iris switch to A (Auto).
- Flickering may increase at ELC under fluorescent lights.

33 Electronic Shutter Synchro-Scan Setting [Synchro Scan: 60.34 Hz - 15.75 kHz]

This setting is possible only when Electronic Shutter Mode Setting 31 is at S/Scan.

Bar noise can be reduced by synchro-scan adjustment in shooting workstation scenes, for example.

- * For luminance setting at each shutter speed and synchro-scan shutter speed, refer to the table on the next page.

Shutter Speed	Synchro-scan	Required luminance ratio
OFF	—	1
1/100	99.68 Hz	2
1/250	250.0 Hz	4
1/500	492.2 Hz	8
1/1 000	984.4 Hz	16
1/2 000	1.969 kHz	32
1/4 000	3.938 kHz	64
1/10 000	7.875 kHz	160

34 CCD Read Out Mode Setting [Field/Frame: Field/Frame 1/Frame 2]

Field: CCD storage will be by field storage.

Frame 1: Vertical resolution increases in frame storage.

Frame 2: Vertical resolution is raised without increasing residual images by frame storage and electronic shutter.

35 Gain Up Setting [Gain: AGC HIGH / AGC LOW / 0 dB - 30 dB / N/Eye L / N/Eye H]

AGC LOW: The Auto Gain Up control with a maximum gain increase of about 18 dB adjusts the luminance automatically.

AGC HIGH: The Auto Gain Up control with a maximum gain increase of about 30 dB operates. If the luminance is still insufficient, the Night Eye also adjusts the luminance automatically.

0 dB: 0 dB should be selected in normal cases.

1 dB - 30 dB: Use this range if sufficient video output cannot be obtained even when the lens iris is opened in shooting dark scenes.

N/Eye L / N/Eye H (Night Eye L/H): Use this mode if sufficient video output cannot be obtained even if 30 dB gain up should be selected.

Night Eye can be selected to any of two (L or H) levels.

Notes

- Only 0 dB, 9 dB, or 18 dB, AGC LOW, AGC HIGH can be selected in case of using the RCU (RCB). If the lens iris switch is at MANUAL, when operating the camera alone or when the iris switch on the RCU (RCB, Hybrid control panel) is at AUTO, AGC may not function.
- AGC HIGH when the AGC selection switch on the hybrid control panel is at AGC.
- 0 dB when the manual gain switch on the hybrid control panel is at LOW, 9 dB when it is at MID, or 18 dB when it is at HIGH.

Manual GAIN AGC

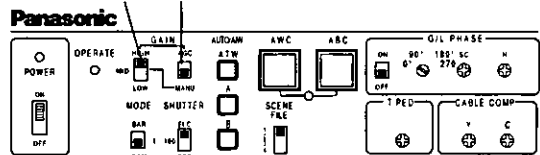

Hybrid Control Panel

36 **Black Level Setting [Pedestal: -30 - +30]**

The black level (pedestal) of the luminance (Y) signal can be set. Used in adjusting the black levels of two or more cameras.

37 **Chroma Level Adjustment [Chroma Level: -3 - +3]**

Chroma Level can be decreased or increased to three levels.

38 **White Balance Setting [White Bal: ATW/AWC A/ AWC B/P SET 3 200K/P SET 5 600K]**

ATW: The white balance is automatically adjusted to the optimum position.

AWC A, AWC B: Color temperature conditions at two points can be stored at AWC A and AWC B. Once the white balance is adjusted with the Item/AWC switch on the back of the camera, it is no longer necessary to set the white balance again if you simply select AWC A or AWC B, provided that the camera is used under the same conditions.

Fine color adjustment can be made after setting AWC by red/blue gain adjustment in Painting Setting 40 or from the RCU (RCB).

P SET 3 200K: The white balance is adjusted to 3 200K illumination.

P SET 5 600K: The white balance is adjusted to 5 600K illumination.

Note

Neither P SET 3 200K nor P SET 5 600K can be set from the RCU (RCB) or the hybrid control panel.

39 **Highlight Chroma Setting [Highlight Chroma: OFF/LOW/HIGH]**

At LOW or HIGH, the color dynamic range widens to prevent highlighted white portions from suppression.

40 **Painting Setting [Painting: R Gain, B Gain, R Pedestal, B Pedestal: -30 - +30] R Gain, B Gain:**

Fine adjustment of the white balance can be made after AWC setting when AWC A or AWC B is selected in White Balance Setting 38. In case of using the RCU (RCB), use the R/B gain controls for this purpose. The set value returns to ± 0 after AWC setting in using the camera alone.

R Pedestal, B Pedestal:

Fine adjustment of the black balance can be made after ABC setting.

In case of using the RCU (RCB), use the R/B pedestal controls for this purpose. The set value returns to ± 0 after ABC setting in using the camera alone.

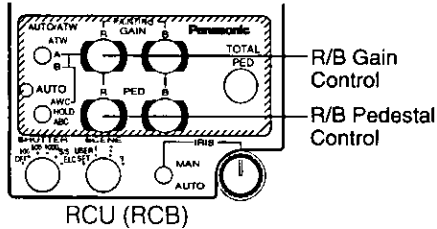

41 2-dimensional Lowpass Filter Setting [2D LPF: OFF/ LOW/ HIGH]

The 2D lowpass filter that reduces moire and cross color can be set.

42 Horizontal Phase Adjustment [H Phase: -206 - +49]

Horizontal phase can be adjusted when a genlock signal is supplied.

43 Subcarrier Phase Coarse Adjustment [SC Coarse: 1/2/3/4]

Coarse adjustment of subcarrier phase can be made when a genlock signal is supplied.

44 Subcarrier Phase Fine Adjustment [SC Fine: -511 - +511]

Fine adjustment of subcarrier phase can be made when a genlock signal is supplied.

45 Color Bar Setup Setting [Color Bar Set: 0.0IRE/ 7.5IRE]

The setup level of color bar can be adjusted.

46 Detail Level Setting [Detail: OFF/LOW/HIGH]

Contour correction quantity can be selected.

Detail settings made using the Horizontal/Vertical Detail Level HIGH/LOW Setting **47**.

47 Horizontal/Vertical Detail Level HIGH/LOW Setting

[H Detail Level H: +1 - +63]

[V Detail Level H: +1 - +31]

[H Detail Level L: 0 - +62]

[V Detail Level L: 0 - +30]

Detail level can be set in horizontal (H) and vertical (V) directions with the Detail Level Setting **46** at HIGH or LOW.

Whichever the direction, H or V, the set level at HIGH must be at least one position higher than that at LOW.

48 Detail Band Setting [Detail Band: 1 - 5]

A contour correction band can be set with the Detail Level Setting **46** at HIGH or LOW. The higher setting, the finer will be the detail.

49 Noise Suppress Compensation Level Setting
[Noise Suppress: 1 - 10]
Screen noise can be reduced with the Detail Level Setting **46** at HIGH or LOW. If the noise suppress compensation level is set too high, a fine object will be reproduced less sharply.

50 Level Dependent Compensation Level Setting
[Level Dependent: 0 % - 25 %]
Screen noise due to the detail of dark parts of an object can be reduced.
If level dependent compensation level is set too high, however, hair, for example, will be reproduced less sharply.

51 Dark Detail Compensation Level Setting [Dark Detail: 0 - 5]
The contours of the darker portions of an object can be emphasized.
This setting is possible only when the Level Dependent Compensation Level Setting **50** is set to 0 %.

52 Chroma Detail Compensation Level Setting
[Chroma Detail: 0 - 15]
The contours of high-hue portions of an object can be emphasized.

53 Skin Color Detail Level Setting [DTL Flesh Tone: LOW/MID/HIGH]
LOW: Skin color coarseness is suppressed.
MID: Standard
HIGH: Skin color is emphasized.

54 Corner Detail Setting [Corner Detail: OFF/ON]
Corner detail, which improves the resolution of corners, can be turned on or off when the Detail Level Setting **46** is at HIGH or LOW.

55 Precision Detail Level Setting [Precision Detail: OFF/LOW/HIGH]
This setting is to narrow detail width and suppress detail glare.

- 55 Color Matrix Compensation Level Setting**
[Matrix (R-G)/(R-B)/(G-R)/(G-B)/(B-R)/(B-G): -31 - +31]
 Color Matrix compensation level can be adjusted.
(R-G): To increase or decrease the intermediate color between red and magenta
(R-B): To increase or decrease the intermediate color between red and yellow
(G-R): To increase or decrease the intermediate color between green and cyan
(G-B): To increase or decrease yellowish green
(B-R): To increase or decrease the intermediate color between blue and cyan
(B-G): To increase or decrease purple
- 57 Gamma Correction Level Setting**
[Gamma: 0.35 - 0.55]
 Gamma correction level can be set.
- 58 Knee Compensation Level Setting [Knee Point: 88 % - 98 % / Dynamic]**
88 % - 98 %: The level of video signals subject to knee compensation (knee point) can be set.
Dynamic: Knee compensation level is automatically adjusted according to the scene.
- 59 White Clip Level Setting [White Clip: 95 % - 110 %]**
 The peak level of video signals to be white-clipped can be set.

- 60 Flare Correction Level Setting [Flare R/G/B: 0 - 100]**
 Flare correction level can be adjusted.
 * Flare correction level has already been adjusted prior to shipment from the factory.
- 61 Black Stretch Setting [Black Stretch: ON/OFF]**
 Black stretch to correct the suppression of black portions at low luminance can be set to ON or OFF.
- 62 Clean DNR Setting [Clean DNR: HIGH/LOW/OFF]**
 Clean DNR effect can be selected.
- 63 PC Control Access Speed Setting [Baud Rate: 1 200bps/2 400bps/4 800bps/9 600bps]**
 This setting is to select a communication speed in controlling the camera from the computer.
- 64 Negative/Positive Selection [Nega/Posi: Posi/ Nega]**
Posi: Normal image
Nega: Image is shown reversed in darkness and color.

Note

When an option card is added, only the composite output and Y/C output will be reproduced in negative image.

SETTING TO INITIAL SET

■ Setting to initial set

In case of the wrong setting in any use mode, take the following steps to return to the initial settings.

- (1) Select [Initialize Data] on the main menu screen of each Use Mode. (See page 29.)
Press the YES/ABC switch, then [Initialize Data] screen shown for about 10 seconds.
- (2) Press the YES/ABC switch within about 10 seconds to return to the initial settings. the existing settings

are initialized, the screen shown at ②, and the camera returns to main menu.

- (3) If the NO/BAR switch is pressed, or if the YES /ABC switch is not pressed, within about 10 seconds, the screen shown at ③, and the camera returns to main menu, and the existing settings are not initialized.

Note

If you are using an option card, the Option Card Setting Submenu will not be initialized even if "Return to Initialize" is performed.

①

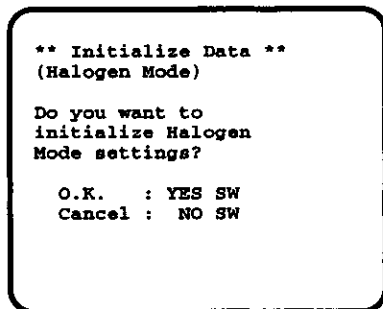

②

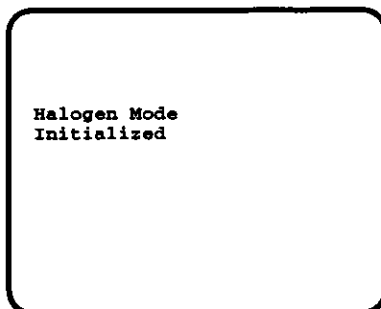

③

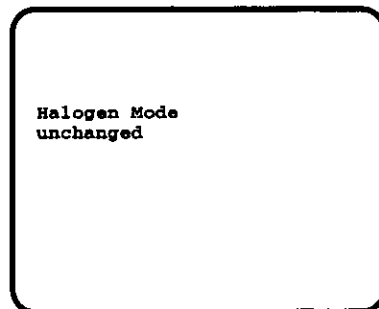

■ INITIAL SETTINGS OF THE SETTING ITEMS (Factory preset values)

● Halogen, Fluorescent, Outdoor Mode

	Item	Halogen mode	Fluorescent mode	Outdoor mode
Brightness Set	Picture Level Light PEAK/AVG Light Area Auto ND (ELC) Auto Gain Up Manu Gain Up Pedestal Contrast (Gamma)	±0 0 Top cut OFF OFF 0dB ±0 MID	±0 0 Top cut OFF OFF 0dB ±0 MID	±0 0 Top cut ON HIGH --- -10 MID
Color Set	Chroma Level Flesh Tone White Bal High-light Chroma	±0 ±0 AWC A OFF	+1 ±0 AWC A OFF	+2 ±0 ATW OFF
G/L. Color Bar Set	H Phase SC Coarse SC Fine Color Bar Set	±0 1 ±0 7.5 IRE	±0 1 ±0 7.5 IRE	±0 1 ±0 7.5 IRE
Sharpness (DTL) Set	DTL Select Level Noise Suppress Clean DNR DTL Flesh Tone	Sharpness HIGH OFF OFF MID	Sharpness HIGH OFF OFF MID	Sharpness HIGH OFF OFF MID
Other Set	Shutter Speed Synchro Scan V Resolution Baud Rate Nega/Posi	OFF --- Normal 9600bps Posi	OFF --- Normal 9600bps Posi	Auto ND --- Normal 9600bps Posi

● User Mode

	Item	User mode		Item	User mode	
Iris, Shutter, Gain Set	Picture Level	±0	Detail Set 2	Chroma Detail	0	
	Light PEAK/AVG	0		Flesh DTL Level	MID	
Color Set	Light Area	Top cut	Color Matrix Set	Corner Detail	OFF	
	Auto Iris Adjust	OFF		Precision Detail	OFF	
	Shutter Mode	Step	Matrix(R-G)	±0		
	Step	OFF	Matrix(R-B)	±0		
	Synchro Scan	---	Matrix(G-R)	±0		
	Field/Frame	Field	Matrix(G-B)	±0		
	Gain	0dB	Matrix(B-R)	±0		
	Pedestal	±0	Matrix(B-G)	±0		
	G/L. Color Bar Set	Chroma Level	±0	Other Set	Gamma	0.45
		White Bal	AWC A		Knee Point	88%
Detail Set 1	High-light Chroma	OFF	White Clip		110%	
	Painting R Gain	±0	Flare R		0	
Detail Set 1	B Gain	±0	Flare G		0	
	R Pedestal	±0	Flare B		0	
Detail Set 1	B Pedestal	±0	Black Stretch		OFF	
	2D LPF	OFF	Clean DNR		OFF	
Detail Set 1	H Phase	±0	Baud Rate		9600bps	
	SC Coarse	1	Nega/Posi		Posi	
Detail Set 1	SC Fine	±0				
	Color Bar Set	7.5IRE				
Detail Set 1	Detail	HIGH				
	H Detail Level H	+11				
Detail Set 1	V Detail Level H	+12				
	H Detail Level L	+7				
Detail Set 1	V Detail Level L	+6				
	Detail Band	2				
Detail Set 1	Noise Suppress	3				
	Level Dependent	0%				
Detail Set 1	Dark Detail	0				

APPEARANCE

Unit: mm (inch)

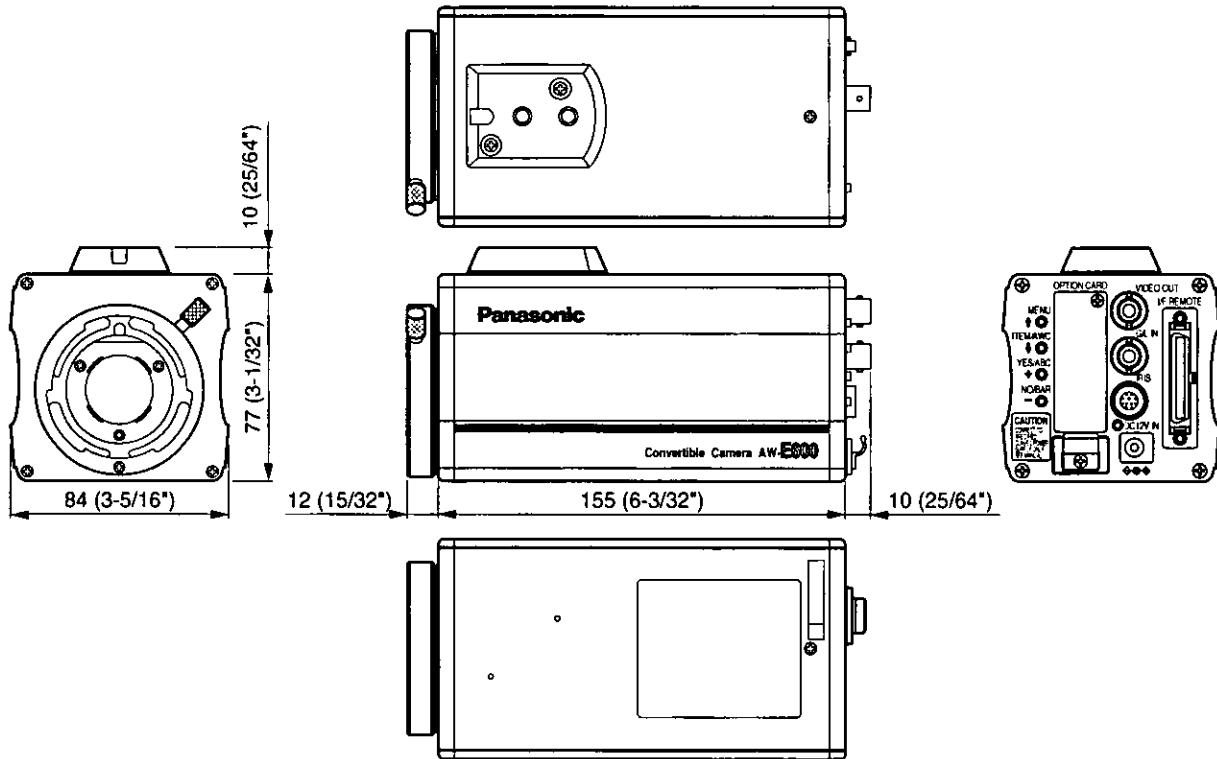

SPECIFICATIONS

Pickup element:	1/2" interline, supersensitive CCDx3
Pixels:	768 (H) x 494 (V) pixels
Scanning:	2:1 interlace
System:	NTSC
Scanning frequency:	15.734 kHz (horizontal), 59.94 Hz (vertical)
Lens mount:	1/2" Standard byonet mount
Synchronizing:	Internal or external
External sync input:	BB, (BNC, 50P D subconnector)
Sensitivity:	2 000 lx, F11, 3 200 K
Minimum illumination:	0.25 lx, F1.4, Night Eye HIGH mode
Signal-to-noise ratio:	65 dB (DNR ON)
Horizontal resolution:	850 TV lines (high band, DTL ON)
Registration:	0.05 %
Contour correction:	Horizontal and vertical
White balance:	Auto (2 memories), 3 200 K, 5 600 K, FINE MANU, ATW
Black balance:	AUTO
Color bar:	SMPTE color bar (Setup 0/7.5)
Shutter speed:	Synchro Scan: 60.34 Hz-15.75 kHz Step shutter: OFF 1/100, 1/250, 1/500, 1/1 000, 1/2 000, 1/4 000, 1/10 000s ELC
Gain:	AGC LOW/HIGH, 0 - 30 dB, NIGHT EYE LOW/HIGH
Iris:	AUTO, MANU
Video output:	Composite: 1 V[p-p] (75 Ω) (BNC, 50P D subconnector) Y: 1 V[p-p] (75 Ω) (50P D subconnector) C: Same as VBS chroma level (75 Ω) (50P D subconnector)
Use mode:	Halogen, Fluorescent, Outdoor, User

Switches:	BACK PANEL: MENU, ITEM/AWC, YES/ABC, NO/BAR MENU ITEM SETTING: Gain, Shutter, White Balance, Detail Level (OFF/LOW/HIGH), Corner Detail, Precision Detail Level, Black Stretch, High Light Chroma, Skin Color Detail, Photometric Measurement Method (ALL/CENTER/TOP CUT/BOTTOM CUT/R/L CUT) CCD Read Out Mode (FIELD/FRAME 1/FRAME 2) Clean DNR, Color Bar Setup, Use Mode, Nega/Posi, PC Control Access Speed
Adjustment function:	MENU ADJUSTMENT: R/B Gain, R/B Pedestal, Black Level, Video Level, Detecting Ratio, Genlock Horizontal Phase/Color Phase, Gamma Compensation Level, Knee Compensation Level, White Clip Level, Horizontal Detail Level, Vertical Detail Level, Detail Band Level, Noise Suppress Compensation Level, Level Dependent Compensation Level, Chroma Detail Compensation Level, Dark Detail Compensation Level, Matrix Compensation Level, Flare Correction Level
Source voltage:	DC 12 V
Power consumption:	9.6 W
Operating temperature:	-10°C to +45°C (14°F to +113°F)
Operating humidity:	30 % to 90 %
Dimensions:	84 (W) x 77 (H) x 155 (D) mm [3-5/16" x 3-1/32" x 6-3/32"]
Weight:	0.86 kg
Finish:	AV ivory painting (Munsell 7.9Y 6.8/0.8 or equivalent)

Weight and dimensions indicated are approximate.
Specifications are subject to change without notice.

STANDARD ACCESSORIES

Body cap	1
Rubber Sheet	1

OPTIONAL ACCESSORIES

Pan/Tilt Unit	AW-PH300	Studio Cable	WV-CA26U15
Pan/Tilt Unit AC Adaptor	AW-PS300		WV-CA26U30
Hybrid Control Panel	AW-RP501		WV-CA26U100
Multi Hybrid Control Panel	AW-RP505	Cable Joint Adaptor	WV-CA26T26
Multi Port Hub	AW-HB505	RCB Cable	AW-CA50T10
Control Panel AC Adaptor	AW-PS301	RCU Cable	AW-CA50A26
AC Adaptor	AW-PS505	Pan/Tilt Unit Cable	AW-CA50T15
Remote Control Unit	WV-RC700A	PC Control Camera Pan/Tilt Unit Cable	AW-CA50A15
	WV-RC550	PC Control Pan/Tilt Unit Cable	AW-CA28T9
Remote Control Box	WV-CB700A	PC Control Cable	AW-CA50T9
Camera Mounting Bracket	WV-831	DC Power Cable	AW-CA4T1
RCU Rack Mount Frame	WV-Q70	RGB Cable	AW-CA50T6
VF Mounting Bracket	AW-Q40	Studio Card	
Connection Cable	WV-CA9T5	(RGB, YPr-YPb Outputs)	AW-PB301
	(D sub	Studio Card	AW-PB305
	9p-BNC,	RGB Card	AW-PB302
	approx. 5 m)	1/2" Byonet Zoom Lens (14X)	AW-LZ14XBMD

Panasonic

PANASONIC BROADCAST & DIGITAL SYSTEMS COMPANY
DIVISION OF MATSUSHITA ELECTRIC CORPORATION OF AMERICA

Executive Office: 3330 Cahuenga Blvd W., Los Angeles, CA 90068
(323) 436-3500
One Panasonic Way 4E-7, Secaucus, NJ 07094 (201) 348-7621

EASTERN ZONE: One Panasonic Way 4E-7, Secaucus, NJ 07094 (201) 348-7621

Mid-Atlantic: One Panasonic Way 4E-7, Secaucus, NJ 07094 (201) 348-7621

Southeast Region: 1225 Northbrook Parkway, Ste 1-160 Suwanee, GA 30024
(770) 338-6845

Central Region: 1707 N Randall Road E1-C-1, Elgin, IL 60123 (847) 468-5200

WESTERN ZONE: 3330 Cahuenga Blvd W., Los Angeles, CA 90068 (323) 436-3500

Dallas Region: 6226 Abington Way, Houston, TX 77008 (713) 802-2726

Government Marketing Department: 52 West Gude Drive, Rockville, MD 20850 (301) 738-3840

PANASONIC CANADA INC.

5770 Ambler Drive, Mississauga, Ontario, L4W 2T3 (905) 238-2115

PANASONIC SALES COMPANY

DIVISION OF MATSUSHITA ELECTRIC OF PUERTO RICO, INC.

San Gabriel Industrial Park, 65th Infantry Ave., KM9.5 Carolina, Puerto Rico 00630 (809) 750-4300

6